

Understanding Retrocausality

-- and Losing a Wager

Can a Message Be Sent To the Past?

Richard Shoup

Boundary Institute
San Jose, California, USA

rshoup@boundary.org

Copyright © 2011 - All Rights Reserved

Overview

- Introduction & the wager
- Downgrading "Causality"
- Values & Constraints
- Superposition & Relations
- Preparation & Measurement
- Backwards signaling?
- Challenging experiments
- About Time?
- Summary & Comments



R. Shoup - AAAS, June '11

Boundary Institute

The Wager (2006)

"Within 5 years (by June 21, 2011), an experiment demonstrating transfer of information backwards in time [via OM] will be conducted and published ... The loser will host a dinner at the oldest high-quality restaurant in the city of the next conference where all three participants are able to be present."

R. Shoup - AAAS, June '11

Boundary Institute

Basic EPR with SR

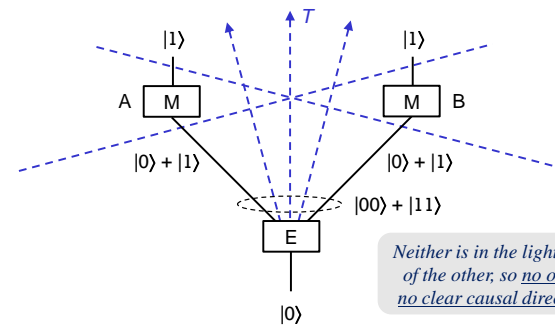

R. Shoup - AAAS, June '11

Boundary Institute

Delayed Choice

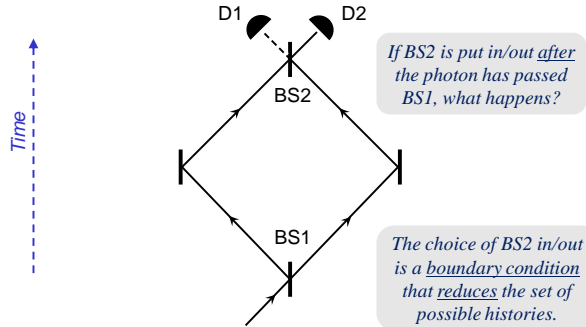

R. Shoup – AAAS, June '11

Boundary Institute

What About Causality?

- In entanglement, order can be observer-dependent
- Dynamical laws of physics are time-symmetric
- Present events are influenced/determined by past and future
 - Double boundary conditions, like least action, etc.
- Causality - obsolete concept both forward and backwards
 - Replace by *influence, dependence, correlation*
 - Bidirectional *relations*, not functions, not inputs or outputs
- Common sense violated? ... *Modify it!*

“The law of causality, I believe, ... is a relic of a bygone age, surviving, like the monarchy, only because it is erroneously supposed to do no harm.”
 -- Bertrand Russell, 1913

R. Shoup – AAAS, June '11

Boundary Institute

Causality \Rightarrow Relations

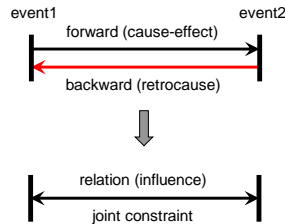

“We may say that there is at present no occasion and no reason to speak of causality in nature – because no [macroscopic] experiment indicates its presence and ... quantum mechanics contradicts it.” -- John von Neumann, 1955

R. Shoup – AAAS, June '11

Boundary Institute

A Value is a Solution to a System of Constraints

- $x = 2 \Rightarrow$ one unique singular value
- $x^2 = 4 \Rightarrow$ two integer values: $+2, -2$
- $\left. \begin{array}{l} x + y = z \\ x \oplus y = z \end{array} \right\} \Rightarrow$ each free, pairwise free, but jointly constrained
- Two slits open \Rightarrow two paths taken:
- Entangled pair \Rightarrow each qubit free: $|0\rangle, |1\rangle$, but jointly just two $|00\rangle, |11\rangle$

R. Shoup – AAAS, June '11

Boundary Institute

Multivalued Constraints

Polynomial:	$x^2 - 1 = 0$	$x^4 + 2x^3 - 2x - 1 = 0$
Multiset:	$x = \{ +1, -1 \}$	$x = \{ +1, -1, -1, -1 \}$
Dirac vector:	$x = 0\rangle + 1\rangle$	$x = 0\rangle + 3 1\rangle$
Matrix/Table:	$\begin{bmatrix} 1 & x & n \\ 0 & 1 & 1 \\ 1 & 1 & 1 \end{bmatrix} \swarrow$	$\begin{bmatrix} 1 & x & n \\ 0 & 1 & 1 \\ 3 & 1 & 3 \end{bmatrix} \swarrow$

R. Shoup - AAAS, June '11

Boundary Institute

Backwards Influence & Superposition

- “Two identical particles evolve differently. Why? There must be some hidden variable or influence, and *this can only come from or be in the future.*” -- Aharonov
- The present is determined by past *and* future.
- The future can only have an effect if the past does not determine the present completely, i.e. *when a superposition exists.*

R. Shoup - AAAS, June '11

Boundary Institute

Relations vs Functions

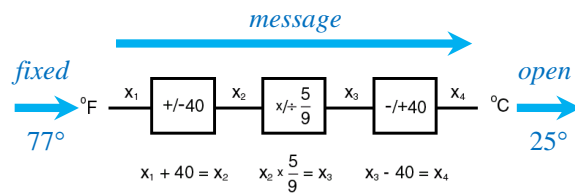

Fahrenheit / Centigrade relation

Today, digital computers are entirely functional, but quantum computers are naturally relational.

R. Shoup - AAAS, June '11

Boundary Institute

Rot and CRot

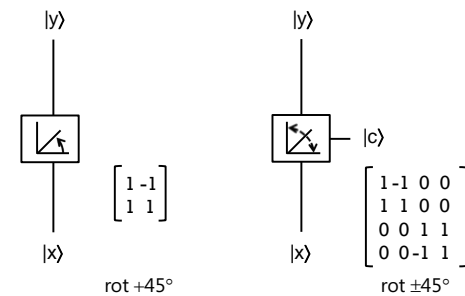

R. Shoup - AAAS, June '11

Boundary Institute

CNot and CEq

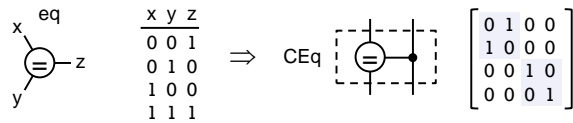
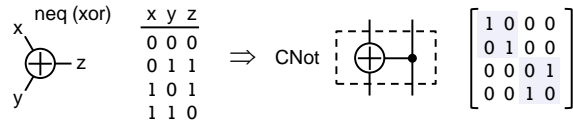

R. Shoup - AAAS, June '11

Boundary Institute

Preparation and Measurement

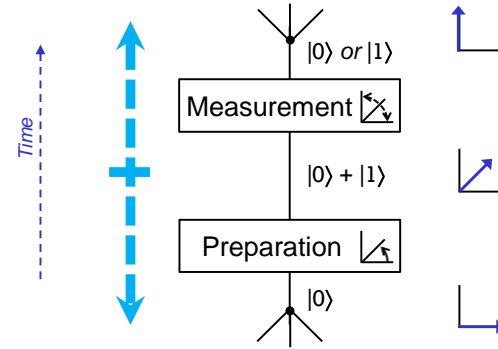

R. Shoup - AAAS, June '11

Boundary Institute

Preparation (Superposition)

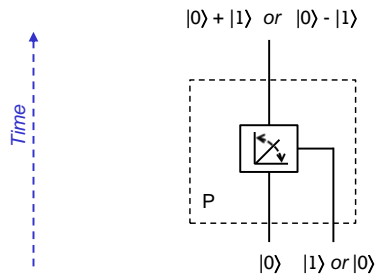

Balanced superposition loses information, tells nothing about its origin.

R. Shoup - AAAS, June '11

Boundary Institute

Postparation (Measurement)

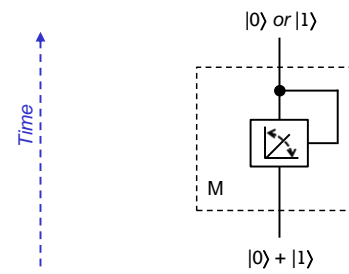

Direction of rotation is determined by the 'output', thus the feedback loop collapses to an eigenvalue.

R. Shoup - AAAS, June '11

Boundary Institute

Retro Signaling via Superposition(1)?

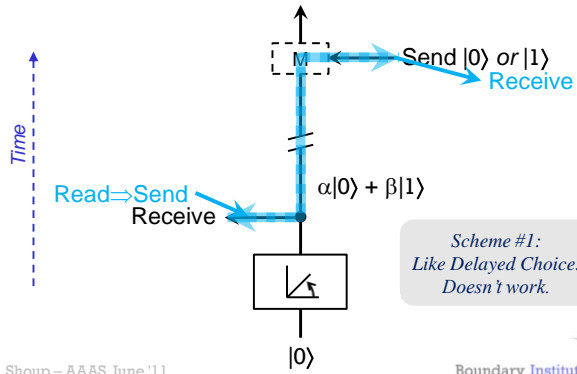

*Scheme #1:
Like Delayed Choice.
Doesn't work.*

R. Shoup - AAAS, June '11

Boundary Institute

Retro Signaling via Superposition(2)?

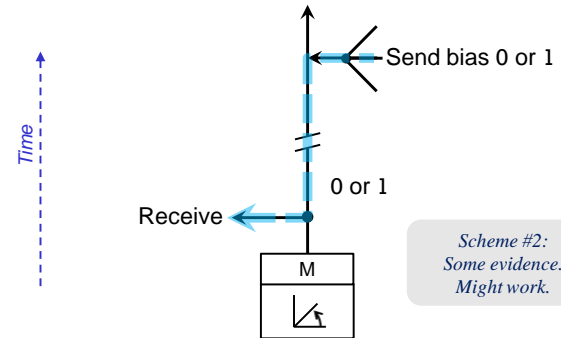

*Scheme #2:
Some evidence.
Might work.*

R. Shoup - AAAS, June '11

Boundary Institute

Entanglement

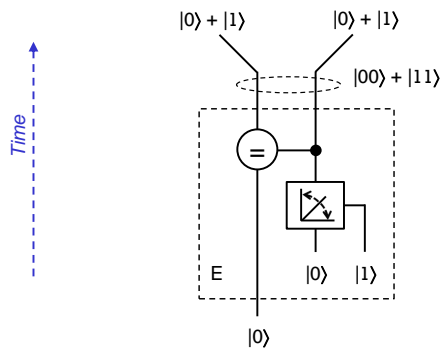

R. Shoup - AAAS, June '11

Boundary Institute

Basic EPR

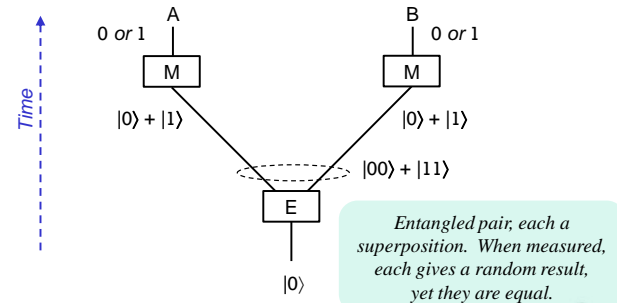

*Entangled pair, each a
superposition. When measured,
each gives a random result,
yet they are equal.*

R. Shoup - AAAS, June '11

Boundary Institute

Retro Signaling via EPR?

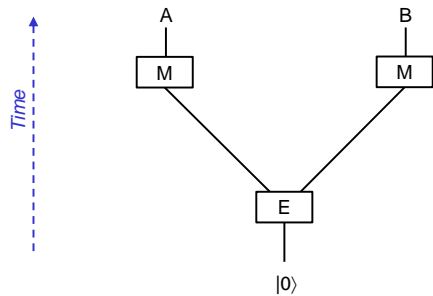

R. Shoup - AAAS, June '11

Boundary Institute

Retro Signaling via EPR?

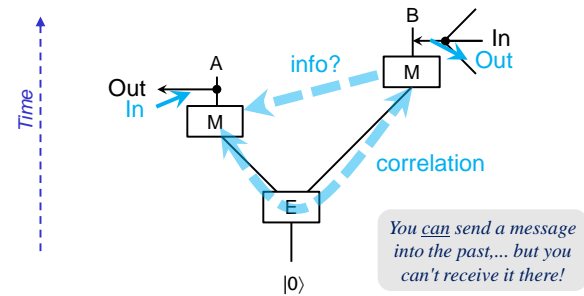

R. Shoup - AAAS, June '11

Boundary Institute

Basic EPR

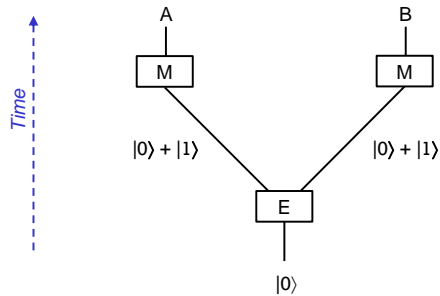

R. Shoup - AAAS, June '11

Boundary Institute

Basic EPR Reversed

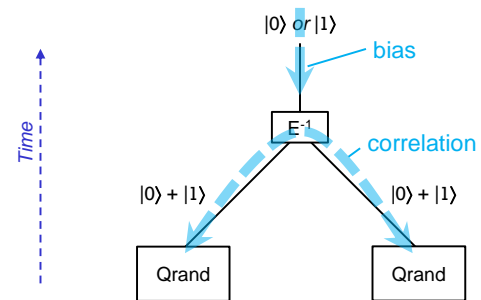

R. Shoup - AAAS, June '11

Boundary Institute

Basic EPR Reversed & Simplified

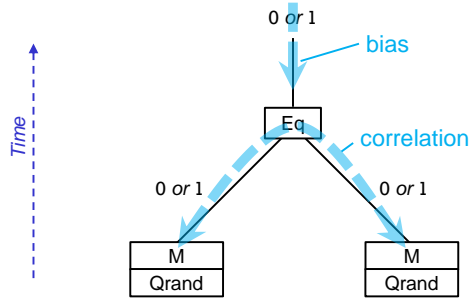

R. Shoup - AAAS, June '11

Boundary Institute

Basic Psi Experiment

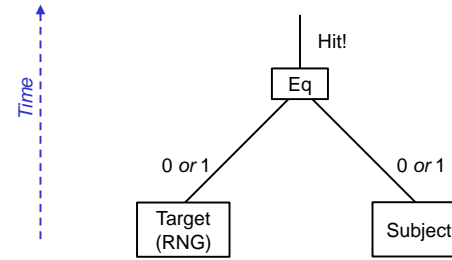

R. Shoup - AAAS, June '11

Boundary Institute

Bem Experiment #1

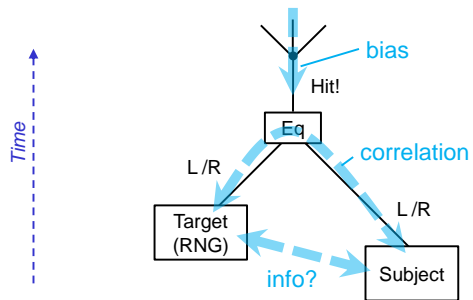

R. Shoup - AAAS, June '11

Boundary Institute

Bem Experiment #1

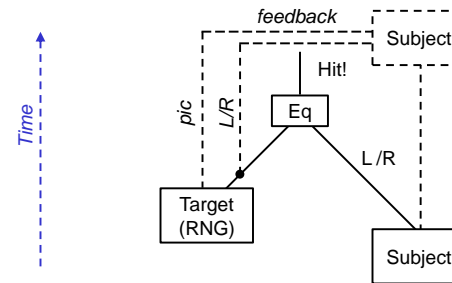

R. Shoup - AAAS, June '11

Boundary Institute

Radin Interferometer Experiment

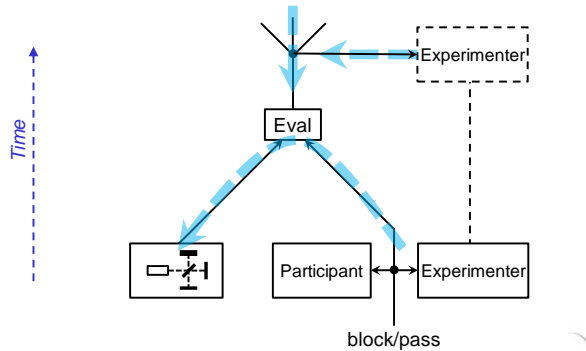

R. Shoup – AAAS, June '11

Boundary Institute

Three Paths to Correlation

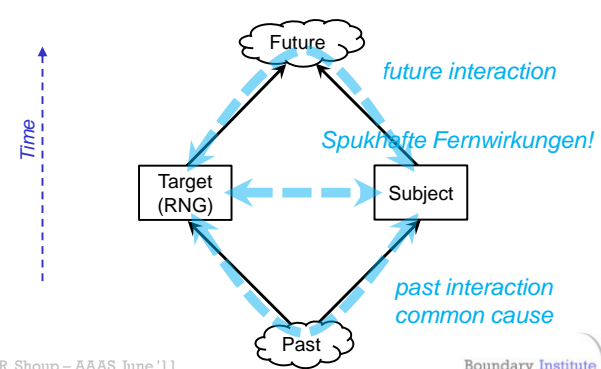

R. Shoup – AAAS, June '11

Boundary Institute

Theory vs Psi Phenomena

- Allows backwards correlation, but *not* info transfer
 - Modest change to quantum theory formalism
- Good agreement/explanation for psi properties (hints)
 - Time/order independence (clairvoyance vs precognition)
 - Complexity independence (goal orientation)
 - Selectivity problem (sensing & affecting)
 - Experimenter/Futures effect (belief, audience)
 - Effect size (small in principle?), unavailable to evolution

R. Shoup – AAAS, June '11

Boundary Institute

Summary

- All values are "real" and definite
 - Sometimes superposed and not aligned with our basis
- Superposition \Leftrightarrow underdetermined
 - Thus open to future constraint/determination
- All transformations are unitary
 - No "collapse", no fundamental randomness
- Time symmetry - relations not functions
 - Relation/constraint: restriction on joint values

R. Shoup – AAAS, June '11

Boundary Institute

Summary II

- “Quantum-random” events such as measurement and radioactive decay are partially determined by *future boundary conditions* and dependencies.
- Underdetermined events (RNGs) in the present *can be correlated* due to *past or future* interactions.
- Correlation due to past or future entanglement *can appear to be information transfer*.
- Correlation due to past or future entanglement *can explain some psi phenomena*.

R. Shoup – AAAS, June '11

Boundary Institute

Was the Wager Actually Lost?

- Not quite 5 years yet (June 21)...
- Participants not all present at this conference...
- Information *is sent* into the past (we argue), however *the message cannot be received there!*
- But the experiment has not been performed, and so *I do concede*, and will pay off forthwith.

R. Shoup – AAAS, June '11

Boundary Institute

Quantum Dynamics

1. **Unitary evolution**
(Schrödinger equation)
 - linear, unitary, conservative, reversible, deterministic
2. **Measurement** (“collapse” of the wavefunction)
 - non-linear, non-unitary, non-conservative, non-reversible, random, unpredictable

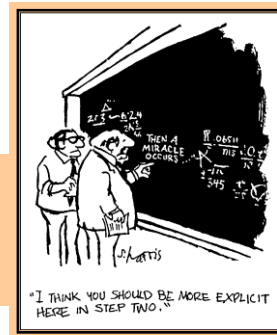

R. Shoup – AAAS, June '11

Boundary Institute

Self-reference, Paradox, and Time

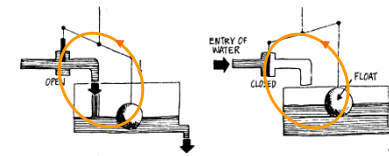

Negative feedback

“All Cretans are liars.” -- Epimenides the Cretan
 “This sentence is False.” -- anonymous
 “The set of all sets not containing themselves.” -- Bertrand Russell
 “This statement is unprovable.” -- Kurt Gödel
 “This program does not halt.” -- Alan Turing

R. Shoup – AAAS, June '11

Boundary Institute

Classical Self-Reference

- Mechanical systems
- Control Theory
- Systems Theory
- Cybernetics
- etc ...

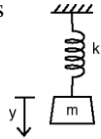

$$y = -\frac{m}{k} \frac{d^2 y}{dt^2}$$

$$= C_1 e^{+i\omega t} + C_2 e^{-i\omega t}$$

$$= C \sin(\omega t + \phi)$$

Negative feedback is commonly used in Eng & Sci,
... but paradox is forbidden in Logic and Set Theory

R. Shoup - AAAS, June '11

Boundary Institute

Self-Reference - Origin of Time

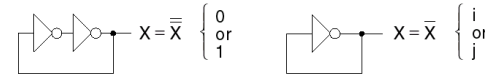

X_{in} -----

X_{out} -----

Autonomy (Memory)

X_{in} [square wave]

X_{out} [square wave]

Antinomy/Paradox (Clock)

R. Shoup - AAAS, June '11

Boundary Institute

Imag Numbers vs Imag Logic Values

Numbers

$$x^2 = -1 \quad (x = -1/x)$$

$$x = \pm\sqrt{-1} = i \text{ or } -i$$

1, -1, i, -i •

ok

Logic

$$x = \sim x$$

$$x = i \text{ or } j$$

F, T, i, j ⊗

not ok!

R. Shoup - AAAS, June '11

Boundary Institute

Discrete Motion



$$v = \frac{n^+ - n^-}{n^+ + n^-} = \frac{p^+ N - p^- N}{N} = p^+ - p^- = 2p^+ - 1$$

- No step size, no time interval, no coordinates
- Prior to Space & Time, just *counting*
 - Example: $v = (29-7)/(29+7) = 0.61$
- Maximum velocity $c = 1$, i.e. one step per tick

(after I. Stein, T. Etter)

R. Shoup - AAAS, June '11

Boundary Institute

Discrete Additive Motion



$$v_1 + v_2 = \frac{p_1^+ - p_1^-}{p_1^+ + p_1^-} + \frac{p_2^+ - p_2^-}{p_2^+ + p_2^-} = \frac{2(p_1^+ p_2^+ - p_1^- p_2^-)}{\underbrace{p_1^+ p_2^+ + p_1^+ p_2^- + p_1^- p_2^+ + p_1^- p_2^-}} \Rightarrow \frac{v_1 + v_2}{1 + v_1 v_2}$$

- When the summed motion = 0, *no time passes*.
- All steps are size 1, and $c = 1$.

(after I. Stein, T. Etter)

R. Shoup - AAAS, June '11

Boundary Institute

Boundary Institute

www.boundary.org

rshoup@boundary.org

R. Shoup - AAAS, June '11

Boundary Institute