

Does God Play Dice? - Part II - Theory and Implications

Richard Shoup

Boundary Institute
Los Altos, California, USA

shoup@boundary.org

Copyright © 2006 - All Rights Reserved

Boundary - Foundations

- Physics
 - Link Theory, causality, randomness, anomalies
- Mathematics
 - Logic, set theory, relations, combinatorics
- Computer Science/Engineering
 - Formal methods in hardware & software design, verification, security
 - Computational math, architecture, representations

Overview

- Randomness, Causality
- Anomalies
- Quantum Theory
- New Theory
- Projects
- Implications



Is Nature Probabilistic?

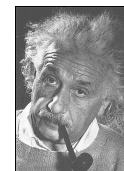

"[QM] yields much, but it hardly brings us closer to the Old One's secrets. I, in any case, am convinced that He does not play dice."
– A. Einstein, letter to Max Born, 1924

"Not only does God definitely play dice, but He sometimes confuses us by throwing them where they can't be seen."

– S. Hawking, 1995

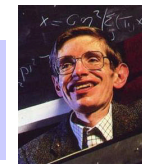

Randomness in Nature

- Macroscopic – apparent, derivative
 - chaos, sensitive/dynamical systems
 - disorder/entropy, thermal, 2nd law of thermo
- Microscopic – fundamental
 - radioactive decay
 - quantum tunneling
 - zero-point fluctuations

Applications of Randomness

- Fair distribution of risk or reward (lottery)
- Cryptography, coding, compression, security
- Sampling, polling, data reduction
- System testing (verification) and measurement
- Communications (routing, timing, ethernet)
- Algorithms (approximation, simulation)
- Strategy, tactics (games, military)

Applications of Randomness...

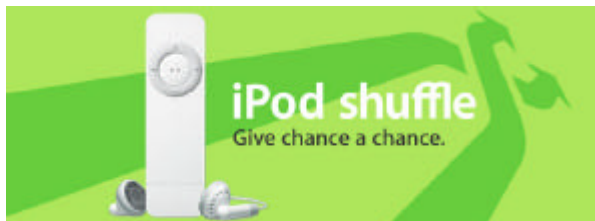

Random is the New Order

Welcome to a life less orderly. ... iPod shuffle rejects routine by serving up your favorite songs in a different order every time. ... Daily gridlock feels less mundane when you don't know what song will play next. iPod shuffle adds musical spontaneity to your life. Lose control. Love it. -- Apple iPod ad copy 4/05

Global Randomness



"We've heard that a million monkeys at a million keyboards could produce the complete works of Shakespeare. Now, thanks to the Internet, we know that is not true."

-- Robert Wilensky

Electronic Randomness

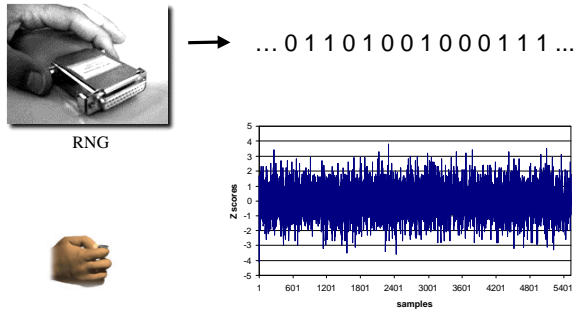

Uninfluenceable, Unpredictable

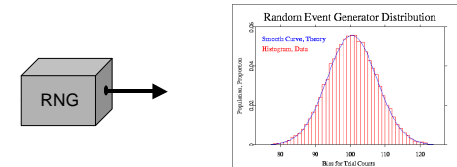

Tests: Diehard, NIST, ComScire, etc.

Global Consciousness Project



>70 true-random RNGs around the world
 200 bits / sec / RNG = >1 Gb / day
<http://noosphere.princeton.edu>

Anomalous Behavior in the GCP network of Random Generators on September 11, 2001

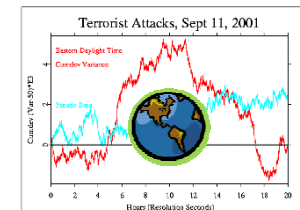

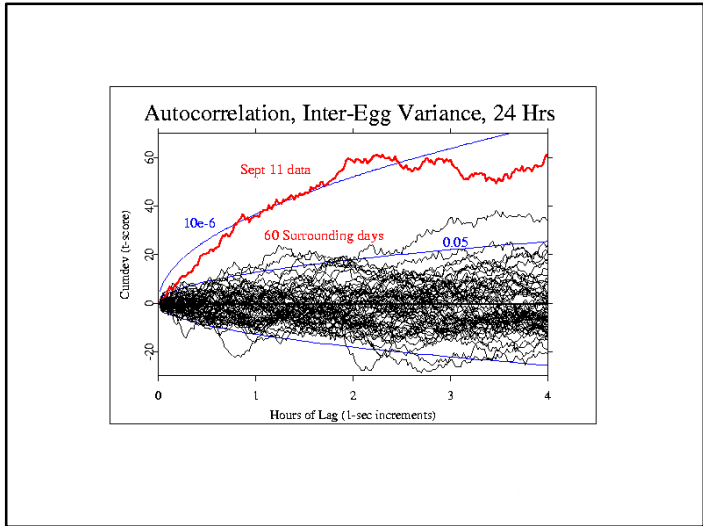
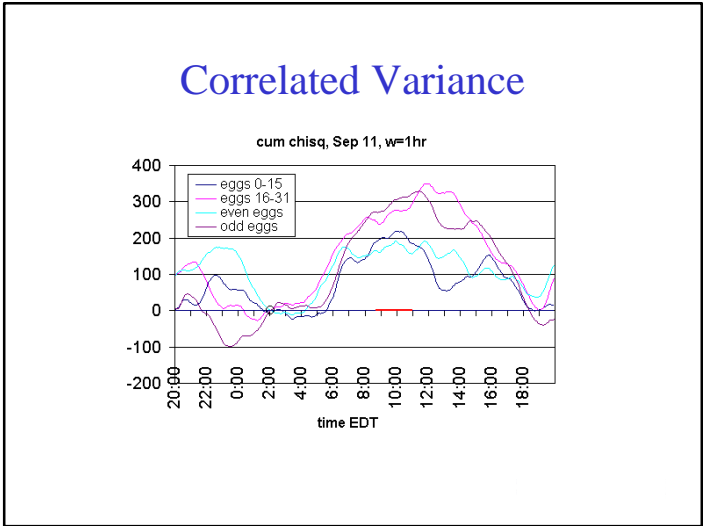
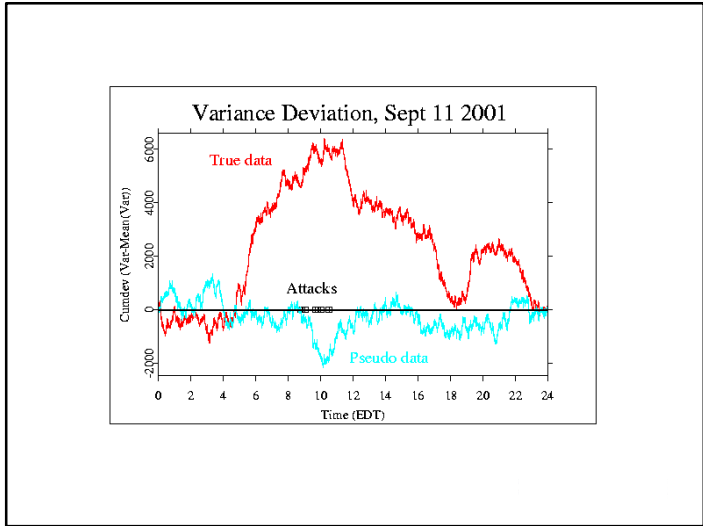

FOUNDATIONS OF PHYSICS LETTERS
 VOL. 15, NO. 6, DECEMBER 2002

CORRELATIONS OF CONTINUOUS RANDOM DATA WITH MAJOR WORLD EVENTS

R. D. Nelson,^a D. L. Radin,^b R. Shoup,^c P. A. Hancoff^d

^aDepartment of Mechanical and Aerospace Engineering
 Princeton University
 Princeton, New Jersey, 08541, USA
 E-mail: rdnelson@princeton.edu

^bInstitute of Avionics Sciences, Palmdale, California, 91302

^cBoeing Institute, Los Angeles, California, 91002

^dIAS, rue St. Maurice, Paris, France F-75013

Received 18 July 2002; revised 4 October 2002

The interaction of consciousness and physical systems is most often discussed in theoretical terms, usually with reference to the system-level and ontological challenges of quantum theory. Less well known is a growing literature reporting experiments that examine the mind-matter relationship empirically. Here we describe data from a global

Simple Experiment

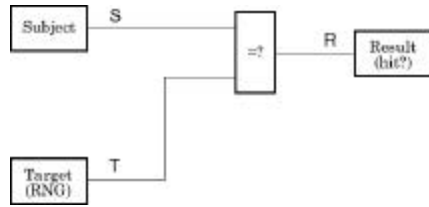

Boundary Institute

Welcome to the Boundary Institute's on-line psi tests

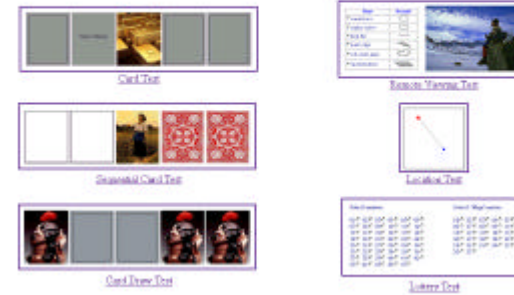

www.boundarylab.org
www.gotpsi.org

Physics vs Parapsychology

- Parapsychology is a respectable science
 - Parapsychological Association - AAAS member since 1969
 - Peer-reviewed journals: JP, JASPR, JSPR, EJP, JSE, others
 - Controlled laboratory experiments, repeatable
 - telepathy, clairvoyance, precognition, psychokinesis
 - NOT fortune-telling, UFOs, bigfoot, etc, etc.
- But we're doing *physics*
 - Anomalies (cf. Michelson-Morley, perihelion of Mercury, etc, etc.)
 - New foundations of Quantum Mechanics, and more
 - New foundations for mathematics, computer science

"I like to keep an open mind, but not so open my brains fall out."
 -- Arthur Sulzberger, Chairman, New York Times

Card Guessing

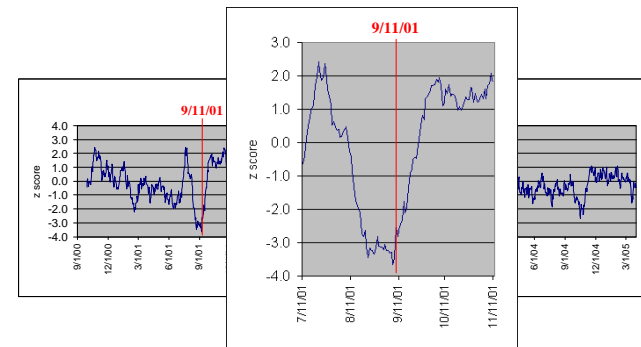

Simple Experiment

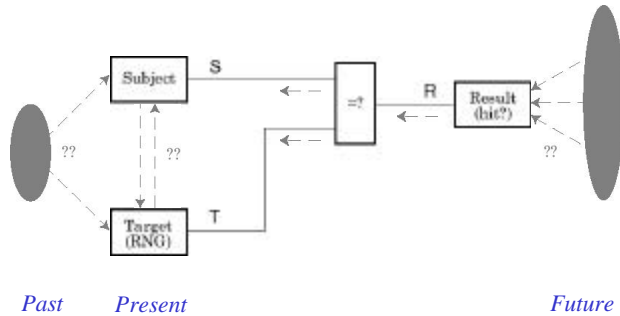

Simple Experiment w offsets

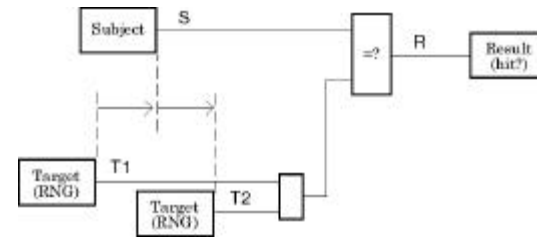

Card Guessing, T1 & T2

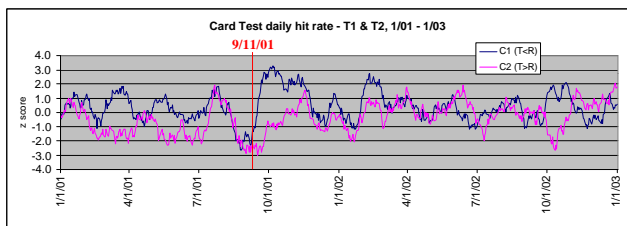

What is the evidence telling us?

- Something is wrong with our assumptions about *cause and effect*, and *randomness*.
- Science is all about *the data* – the evidence.
 - The data don't care about your theories.
- Do not discard data without a *really* good reason ... *especially* data you don't like.

"The way to do research is to attack the facts at the point of greatest astonishment."
-- Celia Green

Influence on the Targets?

user AH, 1/14/06, total 1201 trials, 284 hits (23.6%), odds = 919.8 to 1



user AH, 3/23/06, total 820 trials, 204 hits (24.9%), odds = 2597.5 to 1

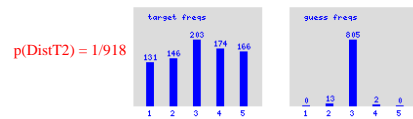

Strange?

"If you haven't found something strange during the day it hasn't been much of a day."
-- John A. Wheeler

"If at first the idea is not absurd, then there is no hope for it."
-- Albert Einstein

"We have to do it while it still seems crazy!" -- Pierre St. Hilaire

Impossible??



"Needless to say, [paranormal phenomena such as precognition] would be just as upsetting in quantum mechanics as in classical physics; If genuine, they would require a complete revamping of the laws of nature as we know them."

-- Murray Gell-Mann, The Quark and the Jaguar

Quantum Dynamics

- Unitary evolution**
(Schrödinger equation)
 - linear, unitary, conservative, reversible, deterministic
- Measurement** ("collapse" of the wavefunction)
 - non-linear, non-unitary, non-conservative, non-reversible, random, unpredictable

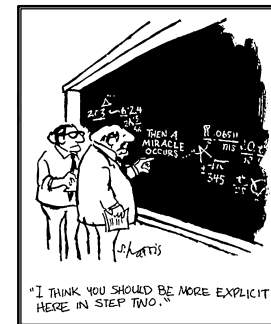

Measurement Interaction

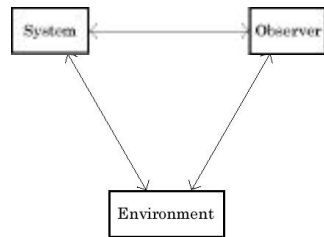

New Theory

- Effects can be understood without a lot of new physics
 - QMeasurement is *unitary* -- no “collapse”
 - Influence forward and backward (*relational*)
 - Events are connected through *past* or *future* interactions
- RNG is best thought of as an *empty box*
 - No such thing as causeless action
 - Reflection of everything connected to it
 - Tail wags the dog ...

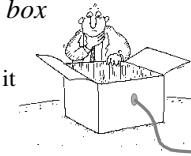

Simple Experiment

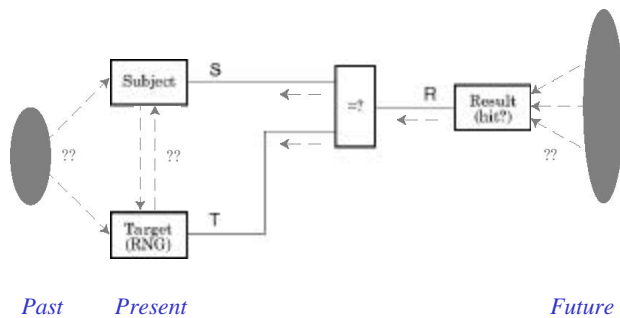

What About Causality?

- Common sense, cause *before* effect?
- Laws of physics are time-symmetrical
 - Exception?: random “collapse” of the wavefunction
- Bidirectional *relations*, not functions
- Bidirectional connections (*links*), not inputs or outputs
- Causality => *influence, dependence, correlation*

“All philosophers imagine that causation is one of the fundamental axioms of science, yet oddly enough, in advanced sciences ... the world ‘cause’ never occurs.... The law of causality, I believe, ... is a relic of a bygone age, surviving, like the monarchy, only because it is erroneously supposed to do no harm.”

-- Bertrand Russell, 1913



Pacific Division

87th ANNUAL MEETING
UNIVERSITY of SAN DIEGO
San Diego, CA
June 18 - 22, 2016

SYMPOSIA

Frontiers of Time: Retrocausation - Experiment and Theory

Organized by Daniel P. Sheehan, Dept of Physics, USD

Tue -Thu, June 20-22

Link Theory

- Theory of composite *Relations*, joint constraints
- *Case counts*, restrictions on set of *possibilities*
- Bi-directional, *symmetrical*, timeless
- Single paradigm: logic, arithmetic, statistics, Qcomp, ...
- Show how *core laws of QM are just mathematics*
 - Predict quantum probabilities, explain the uncertainty principle

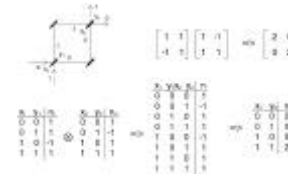

Case Counts & Domains

all Is : independent, uncorrelated
 one 1 : selector, state, classical
 more than one 1 : logic, relation, superposition
 one or more >1 : statistics, multisets, don't cares
 both + and - : quantum realm, interference

x	y	n ₀	n ₁	n ₂	n ₃	n ₄
0	0	1	0	0	1	1
0	1	1	0	1	2	1
1	0	1	0	0	2	-1
1	1	1	1	1	1	1

Projects seeking funding

- Theory: Link Physics Project
 - Conceptual unification of physical measurement
 - New paradigm for all of physics
- Experiments:
 - Markov chain of RNGs
 - RetroComm optical RNG
- Analysis – database of over 70M trials
- Chance@home, Physical Variables, many more...

The Link Physics Project



H. Pierre Noyes
*Emeritus Professor, Stanford Linear Accelerator Center
 Former head of SLAC Theory Group*



James Lindesay
*Professor of Physics, Howard University
 Director, HU Computational Physics Laboratory
 Visiting Professor, SLAC*



Thomas Etter
*Boundary Institute
www.linkphysics.org*

Link Physics

- Goal: Unification of 3 views of physics
 - classical (Newton, Maxwell, Einstein)
 - Markovian statistical
 - quantum mechanical
- Link Theory – formalism representing classical, quantum, and other states
- Quantum Core as pure math, structure
- Implications for the rest of physics

Open Problems

- Relativity vs Quantum Mechanics
 - String Theory? Quantum Gravity?
- Particle physics: origin of coupling constants, mass ratios, etc
- Cosmology: dark matter & energy, inflation, coherence of background radiation, etc

Markov Chain Experiment

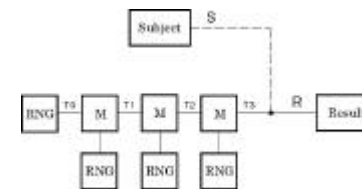

- Chain of randomizers
- Backward propagation of influence?
- Current, many users on-line

RetroComm experiment

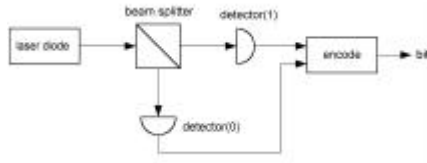

- Goal: Unequivocal demonstration of backwards influence on an optical RNG
- Supermajority & other codings, analysis
- Will have subject in the lab, many on-line

Chance@Home

- New scientific instrument (telescope array, collider)
- 70 => 10,000+ RNGs on PCs
- 200 => 2,000+ bits/sec, local compression
- Software-based, free/cheap
 - Download, remotely configurable
- Network server, real-time processing & display
- Data factored, public-private, experiments, etc.
- Research consortium, Board, regular reporting, etc.

Relevance - Science

- Potential answers to big questions in physics
 - Particle physics, cosmology, relativity vs QM, more...
- Better understanding of quantum realm, causality, time, etc.
 - Randomness, determinism, free will, etc. seen in a new light
- Keys to explaining many perplexing anomalies & phenomena
 - Deviations in randomness, so-called “psychic” phenomena
- New view of the Scientific Method & experimental protocols
- New tools for engineering, investigating, understanding the world
- Applications: quantum computing, semiconductors, communications, medical, ... many unimaginable now

Relevance - Society

- Deeper connection between Science and human experience
- Psychological mindset, gestalt, philosophical principle:

Functional/unidirectional, cause-and-effect
⇒ usage, control, manipulation, consumption
OR

Relational/bidirectional, mutual influence
⇒ co-existence, cooperation, symbiosis, mutuality

... Which of these is a better model for Science in the 21st Century?

Final Q & A

- Q: Is Quantum Measurement reversible?
A: Yes, if the environment is included.
- Q: Does the wavefunction really “collapse”?
A: No. It’s all unitary evolution.
- Q: Are RNG outputs really causeless?
A: No. They are influenced by future dependencies.
- Q: Can Future events influence the Present?
A: Yes! But usually only in small ways.
- Q: Does God Play Dice?
A: No! Nothing is fundamentally “random”.



www.boundary.org

shoup@boundary.org

etter@boundary.org